



INSTALLATION INSTRUCTIONS

263B-001A, 6" SUPER HOPPER

263C-001A, 8" SUPER HOPPER

263E-001A, 8" SUPER XL HOPPER (10" INLET AND OUTLET)

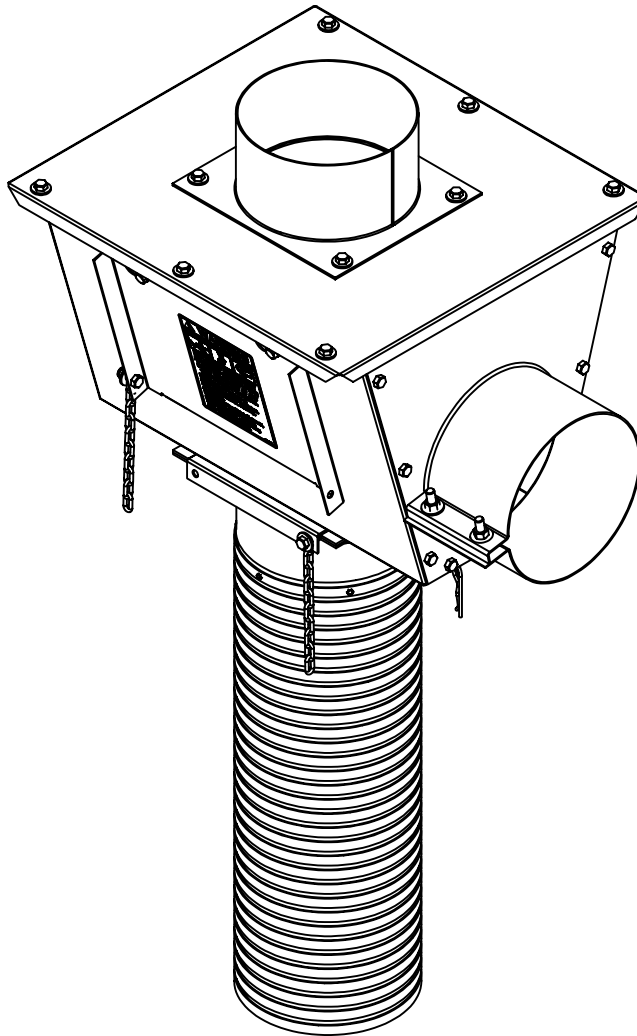

SHIVERS MANUFACTURING, INC

614 W. English St.

Corydon, IA 50060

Ph. (641) 872-1005 ** Fax (641) 872-1593

www.shivers.com

SAFETY

The operator of this machinery must assume the responsibility for his own safety, and that of those who are working with him. He must also make sure that the equipment was installed properly. Factors that contribute to the overall safety of operation are: proper use, maintenance, and frequent inspection of the equipment. All of these are the operator's responsibility.

If any items covered in this manual are not completely understood, or there is a concern with the safety of the product, contact Shivers Manufacturing, Inc. at the address shown on the front page.

Shivers is genuinely interested in providing the safest practical equipment to our customers. If you have a suggestion which you believe will enhance the safety of this product, please write us and let us know.



**TAKE NOTE ANYTIME THIS SYMBOL APPEARS.
YOUR SAFETY, AND THAT OF PERSONS AROUND
YOU IS AT STAKE.**

Anytime you are working with your drying unit, be sure to observe these common sense rules:

- 1). All units must be equipped with a main disconnect switch in close proximity to the grain bin's entry door. It must have the capability of being locked into the OFF position. Disconnect and LOCK OFF all electrical power before conducting any inspection, maintenance, repair, adjustment, or cleaning of the drying and transferring system. When you must have the electrical power on to troubleshoot equipment, do it from a safe distance, and always outside the bin.
- 2). Keep the bin entrances locked at all times. If entering the bin take the lock off the bin entrance and place it on the main disconnect before opening the bin entrance. **Never enter the drying bin unless all power is disconnected and locked off.**

- 3). Always keep all shields and guards in place. If shields or guards must be removed for inspection or maintenance, make sure power is disconnected and locked off. Replace all shields and guards before turning the power back on.
- 4). Do not turn the power on without being sure everyone is clear of all the drying and transferring equipment.
- 5). Make sure that all decals are in place and are easily readable. Do not operate the equipment with missing or illegible decals. If replacements are needed, contact Shivvers Manufacturing, Inc. or your dealer.
- 6). Prior to use, inspect all equipment to insure that it is in good operating condition. Do not operate with missing, damaged, or worn parts.
- 7). Metal edges can be sharp. Wear protective clothing and handle equipment and parts with care.
8. Keep all children and bystanders away at all times.
9. If ascending the bin ladder and/or performing maintenance on the top of the bin, take precautions to prevent accidental falls. It is suggested that when on top of the bin you use a safety harness or other safety device.
10. Periodically review all operating and safety manuals with any personnel working with this equipment. Always train new employees before they operate the drying equipment. Insist that they read and understand the operating and safety manuals.

DON'T TAKE CHANCES!

SLOW DOWN AND DO IT RIGHT!

AUTOMATIC CONTROLS CAN START EQUIPMENT AT ANY TIME!

ACCIDENTS ARE FOREVER!

LOCATION OF SAFETY DECALS

Safety decals are mounted at the factory whenever possible, but it is your responsibility to make sure other decals are installed in the proper places. It is also your responsibility to insure that the decals remain in good, legible condition. You must replace safety decals if they are missing or become illegible. Also, if any new equipment components are installed during repair, the current safety decals are required to be affixed to the replaced component. (For reference to placement of safety decals see owners manual, safety manual, or specific equipment manual)

IMPORTANT: If suggested decal locations, or factory applied decals, are not clearly visible, place decals in a more suitable area. Contact Shivvers Manufacturing for free replacement decals. The part numbers start with a "P-", such as P-10717.

Before applying decals, make sure the mounting surfaces are clean (not oily) and dry.

Review the following decals, and verify that they are in place, are easily readable, and clearly identify the dangers present. Contact Shivvers Manufacturing for free replacement decals or for clarification of any questions you may have.

P-10223

Located on Clean-out Door cover on side of Hopper

SUPER HOPPER
Clean-Out Door & Decal
263-027A

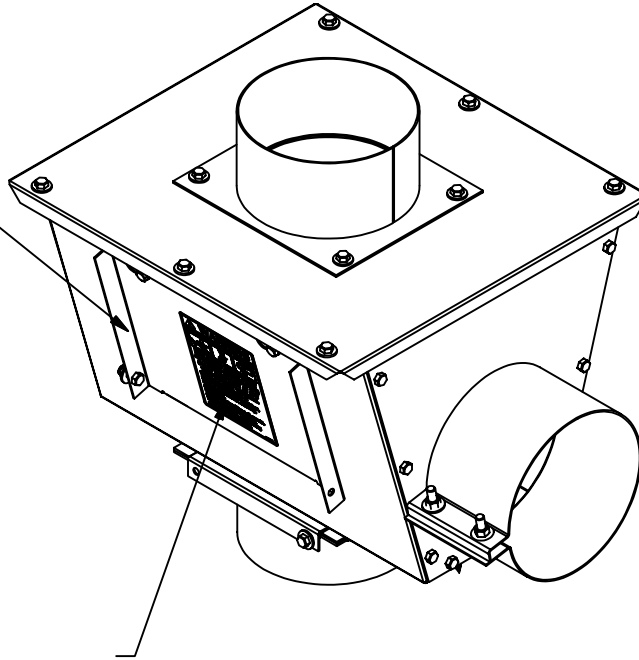

⚠ WARNING

AVOID SERIOUS INJURY OR DEATH

		
---	---	---

**ROTATING EQUIPMENT
AUTOMATIC CONTROLS CAN
START EQUIPMENT AT ANY
TIME WITHOUT WARNING.**

Disconnect and lock out all power before operating clutches, making adjustments, cleaning, or servicing.

Do not operate without all spouts, shields, and guards in place.

Keep hands, feet, and clothing away from moving parts.

P-10223

ASSEMBLING THE SUPER HOPPER

1). Locate the BODY of the Hopper, the SLEEVE END WELDMENT, the BEARING END, and the PARTS SACK FOR SUPER HOPPER from the Parts Box.

Determine which side of the Hopper would be most convenient to place the Clean-out access; since the Sleeve End and Bearing End can be placed on either end of the Body. Once it is determined where the Clean-out Door will be placed, the Sleeve End and Bearing End can then be assembled to the Body. Out of the Parts Sack use sixteen 5/16 x 3/4" bolts, 5/16" Nyloc nuts, and 5/16" washers to secure the ends to the body, eight on each end.

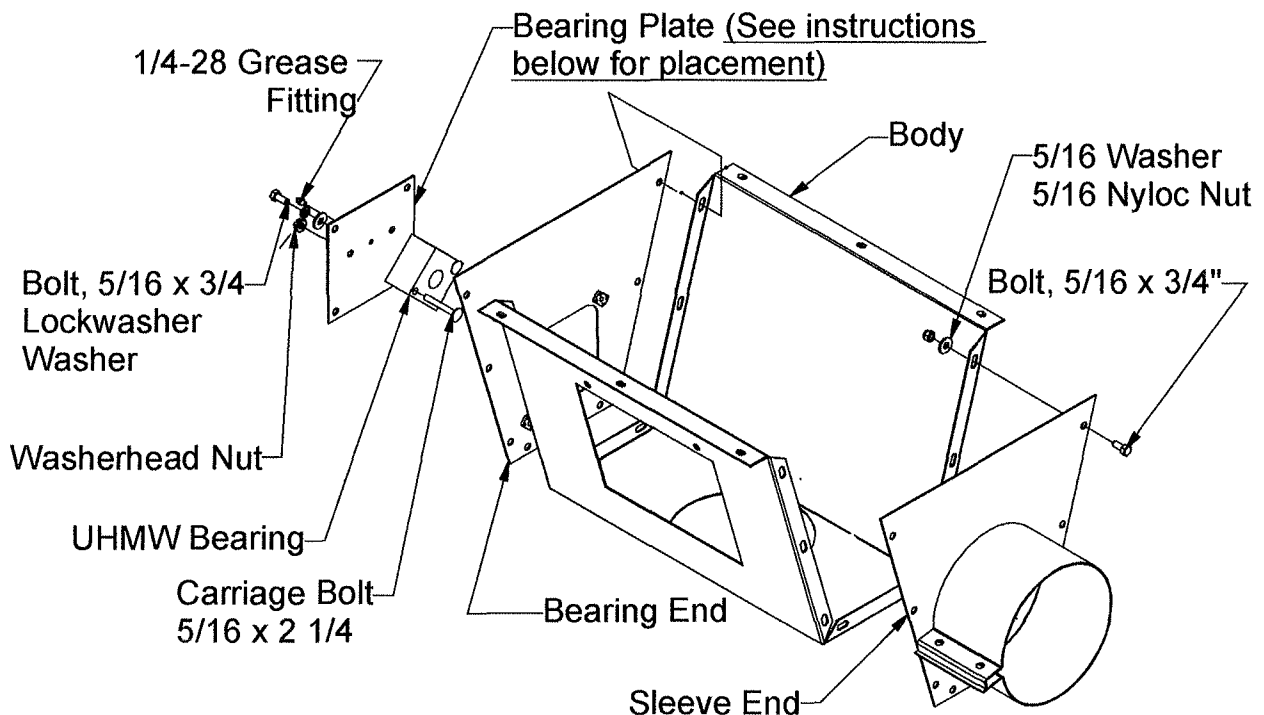

2). Locate in the Parts Sack the UHMW bearing, two 5/16 x 2 1/4 carriage bolts, and two washerhead nuts. Fasten into bearing and the bearing plate as shown, tightening the carriage bolts until the square head sinks into the bearing.

Fasten Bearing Plate to Bearing End using 5/16 x 3/4 Bolts, lockwashers, and washers.

The bearing plate must be rotated so the bearing is one inch higher for the 263C-001A, 8" Super Hopper than for the 263B-001A, 6" Super Hopper.

Do not tighten completely until the Stub Shaft is in place.

3). Locate one of the INLET WELDMENTS, the two SHIMS, four 5/16 x 1" bolts, six Nyloc nuts, ten 5/16" washers, the GATE, the CLEAN-OUT DOOR & WARNING DECAL, the two pieces of 13" LINK CHAIN, two 5/16 x 3/4" bolts, two 5/16 x 3/4" Hex Washer bolts, the 6" SASH CHAIN WITH RING, and the HAIR SPRING PIN.

Fasten the Clean-out Door on to the Body using the two 5/16" Hex Washer bolts making sure that the WARNING DECAL is affixed properly and facing out. Use a 5/16 x 3/4" bolt to fasten a 13" Link Chain piece on to either one of the holes on the Clean-out Door lip. Affix the other 13" Link Chain to the Gate, the lip should be pointing downward, fasten the chain on to the opposite side that was used with the Clean out Door. Loop the Hair Spring Clip through the end of the Sash Chain. Use the end with the Ring to fasten to the Body. Position the Inlet Weldment on the bottom of the Body (narrow end). Place the two Shims between the bottom of the Body and the top of the Inlet Weldment. See Figure below. Use the 5/16 x 1" bolts with a washer on both sides and bolt the Shims, Inlet Weldment, and Chains to the Body. Insert the bottom Gate between the Shims to ensure proper fit and that the Gate will completely close and allow the Hair Spring Clip to be inserted into the back-side hole.

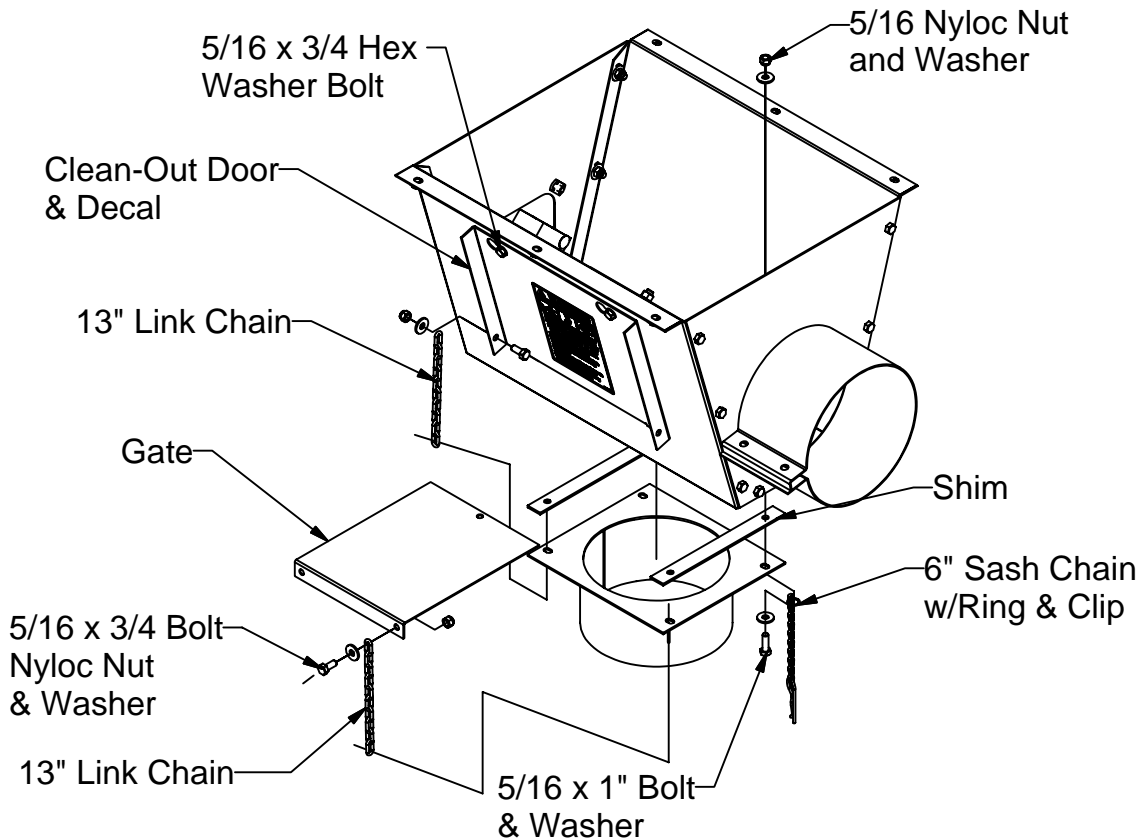

4). Locate the LID, INLET WELDMENT, four 5/16" x 3/4" bolts, eight washers, and four Nyloc nuts.

Bolt the Inlet Weldment to top of the Lid, bent edges of the Lid point down, toward the Body.

5). Locate the Stub Shaft (5 1/2" for 263B-001A and 10 3/4" for 263C-001A and 263E-001A) two 3/8 x 1-3/4" bolts, and two 3/8" locknuts.

Cut the Auger which will be installed in the Hopper so that 18" of exposed fliting will be seen. If the Auger needs to be cut make sure the fliting is welded to the shaft in the vicinity of the cut. Drill two 3/8" diameter holes into the fliting shaft so that they will match the holes in the Stub Shaft. Bolt the Stub Shaft to the end of the fliting so that approximately 1-3/4" of the Stub Shaft is exposed. See Figure below

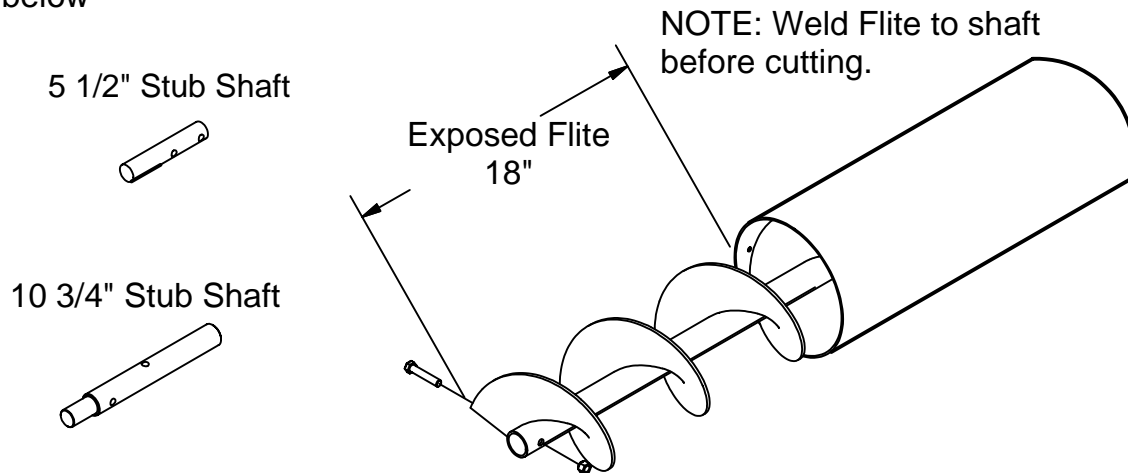

6). Locate two 3/8 x 1-3/4" bolts and two locknuts.

Insert the Stub Shaft end of the Auger into the Sleeve End of the Hopper. Place the Stub Shaft into the UHMW Bearing. Align the Auger and Hopper accordingly. Use the two 3/8 x 1-3/4" bolts to tighten the Sleeve End collar around the Auger tube.

NOTE: The Super Hopper should be installed above the bin opening so that the distance from the bottom of the Hopper Body to the entrance of the bin is no more than 12 inches.

7). Once the Auger has been properly placed in the Hopper, the Lid and Inlet Weldment Assembly may be fastened using 5/16 x 3/4" bolts, washers (one on both sides for lid, one on inside for sides), and Nyloc nuts. The lid for the Super XL Hopper can be turned either way to align the hopper with your system. Make sure that the inlet tube is securely fastened to the Inlet Weldment.

8). The FLEX TUBE can now be installed on the bottom of the Hopper. Locate the Sheet Metal Screws and fasten the Flex Tube to the bottom Inlet Weldment. Never operate unless the bottom Flex Tube and a top inlet tube/spout are installed. IMPORTANT: The bottom Flex Tube should be of sufficient length so that it enters the top of the bin at least 6".

9). If more support is required for the bearing end, see 263-040A Support Bracket sack, with instructions.

MAINTENANCE



WARNING

DISCONNECT AND LOCK OFF ALL ELECTRICITY BEFORE DOING ANY INSPECTION, MAINTENANCE, OR CLEANING.

- 1). To clean out the Super Hopper and/or inspect for maintenance; Make sure all the electricity has been disconnected and locked off!! Make sure that all by-standers are clear before attempting to clean and/or inspect the Super Hopper. If on top of the grain bin, it is recommended that a safety harness and/or other safety equipment be utilized. Ensure that the chains which hold the Clean-out Door and the Gate are securely fastened to the Body of the Hopper. Loosen the two Hex Washer bolts from the Clean-out Door, slide the door to the side and pull up to free it from the Body of the Hopper. Use a stick or other similar object to clear any debris. **NEVER PUT YOUR HAND, ARM OR OTHER BODY PART IN TO THE HOPPER!!!**
- 2). Observe the flighting on the end of the Auger, make sure it has not worn down, damaged, or that any other component is missing. Do not operate with missing, damaged, or worn parts. Observe that the Auger and Hopper are properly aligned.
- 3). Ensure that ALL fasteners are tightened periodically. Including the Sleeve collar holding the Auger tube.
- 4). Return the Clean-out Door by inserting the bottom in first, slide the Door so that the slots fit snugly against the bolts, and tighten the bolts firmly. **NEVER OPERATE WITH THE CLEAN-OUT DOOR OPEN!!**
- 5). Make sure that the inlet tube/spout on top of the Hopper and the outlet tube on the bottom of the Hopper are properly secured before operation. Ensure that the bottom outlet flex tube is at least 6" into the entrance of the grain bin. **ONLY OPERATE WITH THE INLETS AND OUTLETS SECURELY FASTENED TO THE HOPPER.** Operation may proceed with the bottom outlet tube/spout removed only if the outlet Gate is completely closed and fastened.

SUPER HOPPER, 6" AND 8" ASSEMBLY

ITEM	QTY	PART NUMBER	DESCRIPTION	ITEM	QTY	PART NUMBER	DESCRIPTION
1	1	263-013P	Super Hopper Lid	16	2	222-031P	Chain, 13"L x #1/0
2	1	263-010P	Super Hopper Body	17	1	H-2102	Sash Chain with Ring
3	2	263-015W	Inlet Weldment	18	1	F-1469	Pin, Cotter 1/8 X 2-1/2"
4	1	263-014W	Sleeve End WLDT, 6"	19	4	F-1015-15	5/16-18 x 1" Capscrew
	1	263-023W	Sleeve End WLDT, 8"	20	6	F-1231	Self Tapping Screw #8 X 1/2"
5	2	263-019P	Super Hopper Gate Shim	21	1	672-005P	Stub Shaft, 10 3/4"L for 8"
6	1	263-020P	Super Hopper Gate		1	263-006P	Stub Shaft, 5 1/2"L for 6"
7	4	F-1009-03	3/8" Flat Washer	22	1	263-041P	Bearing Plate
8	32	F-1005-02	5/16-18 Nyloc Nut	23	1	263-026P	End Plate Weldment
9	32	F-1546	5/16-18 x 3/4" Capscrew	24	1	262-014P	Bearing, UHMW
10	48	F-1009-02	5/16" Flat Washer	25	2	F-1707	5/16-18 x 2 1/4" Carriage Bolt
11	4	F-1015-28	3/8-16 x 1-3/4" Capscrew	26	1	H-1056	1/4" Grease Fitting
12	4	F-1005-03	3/8-16 Stover Nut	27	2	F-1931	Nut, Serrated Washer, 5/16-18
13	1	ST-9254	Flex Tube, 8" ID X 24" L	28	4	F-1019-02	5/16" LockWasher
14	1	263-027A	Clean-out Door w/Decal P-10223	29	1	263-040A	Support Bracket & Instructions
15	2	F-1212	Capscrew, Washer, 5/16 x 3/4"				

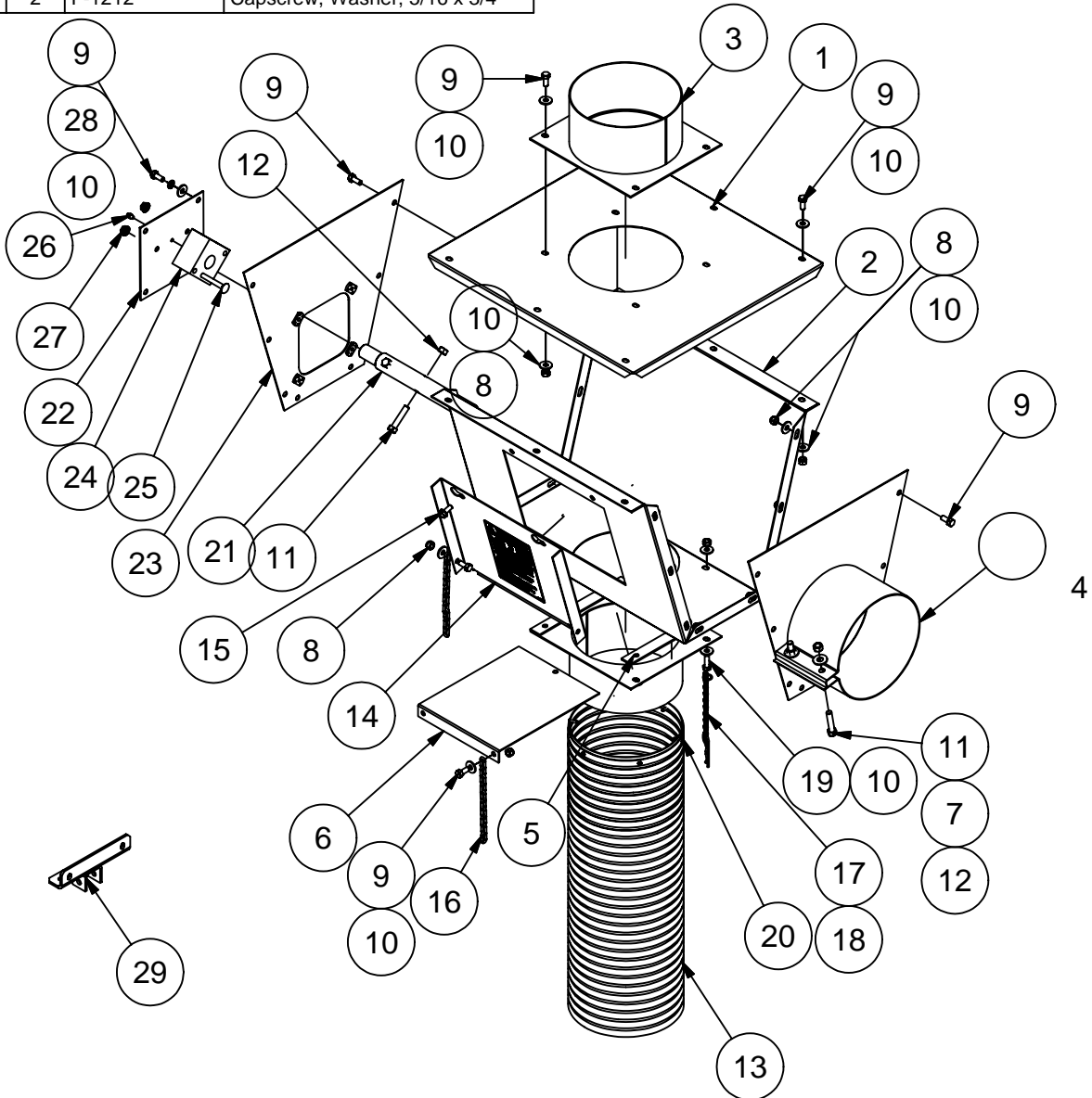

SUPER XL HOPPER, 10" ASSEMBLY

ITEM	QTY	PART NUMBER	DESCRIPTION	ITEM	QTY	PART NUMBER	DESCRIPTION
1	1	263-044P	Super XL Hopper Body	15	1	685B-001A	Flex Tube, 10" x 30"L & Screws
2	1	263-047W	Super XL Hopper Tube End	16	2	F-1212	Capscrew, 5/16 x 3/4"
3	1	263-045P	Super XL Hopper Bearing End	17	12	F-1340	Screw, 1/4 x 3/4
4	1	263-043P	Super XL Hopper Lid	18	4	F-1019-02	5/16" LockWasher
5	1	263-049W	Super XL Hopper Outlet	19	2	F-1707	5/16-18 x 2 1/4" Carriage Bolt
6	1	263-041P	Bearing Plate	20	2	F-1931	Nut, Washer, 5/16-18
7	1	263-051W	Inlet Flange, XL Hopper Lid	21	1	262-014P	Bearing, UHMW
8	32	F-1546	5/16-18 x 3/4" Capscrew	22	1	672-005P	Stub Shaft, Super Hopper
9	32	F-1005-02	5/16-18 Nyloc Nut	23	1	H-1056	1/4" Grease Fitting
10	50	F-1009-02	5/16" Flat Washer	24	2	263-055P	Super XL Gate Shim
11	4	F-1015-15	5/16-18 x 1" Capscrew	25	1	263-056P	Slide Gate, Super XL Hopper
12	1	H-2102	Sash Chain with Ring	26	6	F-1015-28	3/8-16 x 1-3/4" Capscrew
13	2	222-031P	Chain, 13"L x #1/0	27	8	F-1009-03	3/8" Flat Washer
14	1	263-027A	Clean-out Door w/ P-10223	28	6	F-1005-03	3/8-16 Stover Nut
				29	1	263-040A	Support Bracket w/ Instructions
				30	1	F-1469	Pin, Cotter 1/8 X 2-1/2"

